



# CBMAC-100 QUICK REFERENCE

## CBMAC-100 Media Access Center

300 lb.\* [136.4 kg.] Capacity

**APPLICATIONS:** Audio/Video (AV) cabinets and entertainment centers for cabinet openings up to 60" [1524 mm] tall. **This product is covered by U.S. and various foreign patents issued and/or pending.**

**Pullout Box Outside Dimensions:**

Min. Width: 20.75"  
Depth: 18"  
Max. Height: 55"

**Cabinet Opening Inside Dimensions:**

Min. Width: 22.5"  
Depth: 24"  
Max. Height: 60"  
Max. Load Rating: 300 lbs.

	<b>BOTTOM</b>	<b>TOP</b>	<b>Finish</b>	Slides—Black zinc (CB) finish Swivel plates—Black powder coat
<b>Plate Dimensions</b>	18.00" W x 20.81" D [457.2 x 528.6]	18.00" W x 20.81" D [457.2 x 528.6]		
<b>Height</b>	2.44" [62.0 mm]	2.56" [65.0 mm]	<b>Load</b>	300 lbs* [136.4 kg.] per set
<b>Travel</b>	20.00" [508.0 mm]	20.00" [508.0 mm]	<b>Mounting</b>	Brackets
			<b>Hardware</b>	All necessary mounting hardware included. See "Packaging" information on back page.

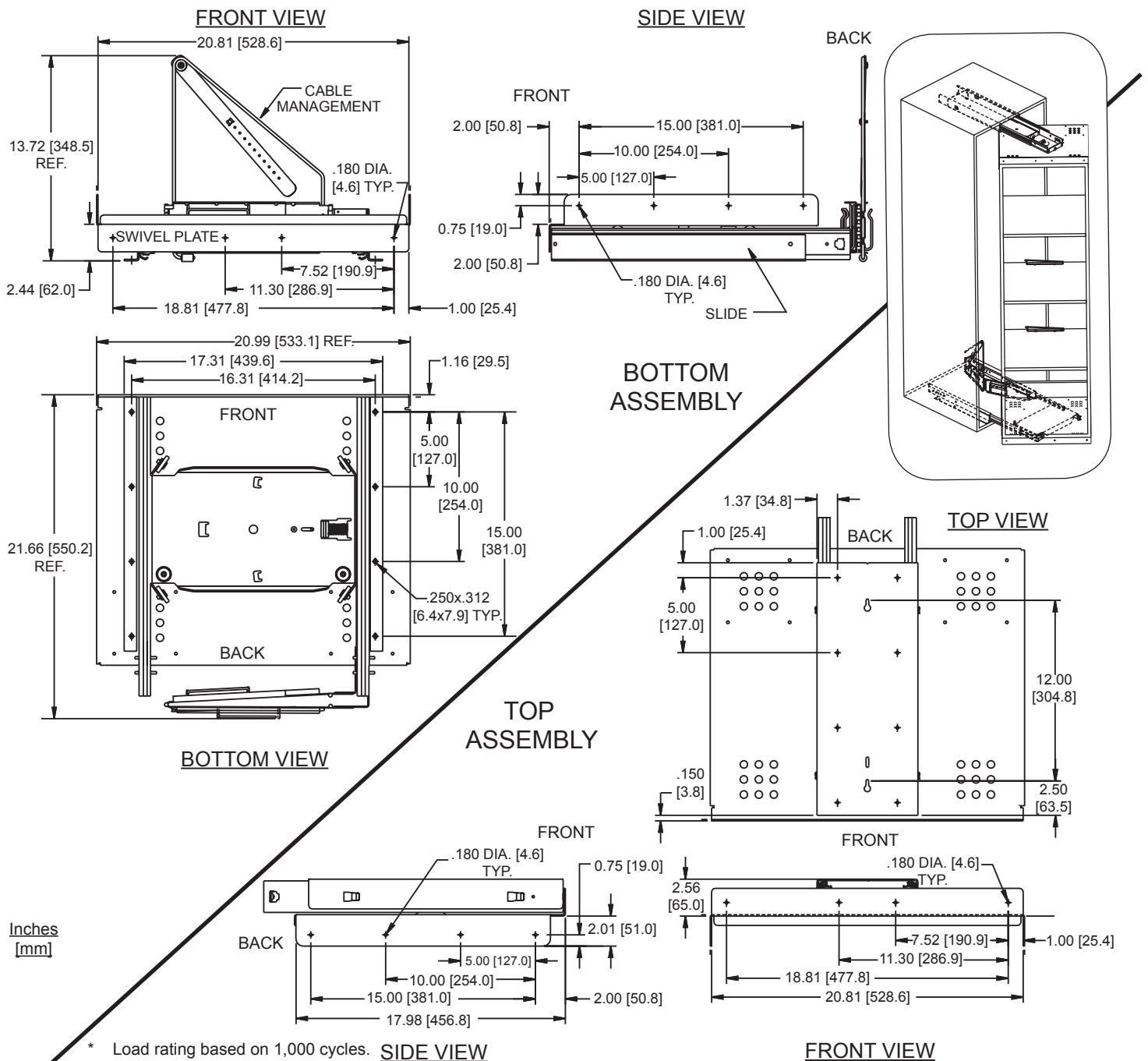

**CAUTION**

The floor and the ceiling of the AV cabinet must be constructed with materials that have good screw holding capabilities. It is recommended that cabinet base and ceiling be a minimum of 3/4"-thick furniture-grade plywood.

The M.A.C. system is designed to fit in a cabinet with a minimum inside width of 22.5" and 24" deep. The maximum height is 60".

The maximum outside width of the pull-out box is 20.75". The maximum depth is 18". The height must be 5" less than the inside height of the AV cabinet. The entire box to be made of 3/4" thick material.

**SWIVEL CLEARANCE**

Be sure to provide the adequate width clearance (min. 28.50") to allow the CBMAC-100 to rotate freely without obstruction. This is especially important in installations near a wall or overhanging pocket door (figure 1).

**TOP ASSEMBLY**

**STEP 1**

From inside of the cabinet, locate and mark the center line of the ceiling from front to rear (see figure 2).

**STEP 2**

Locate and install two #8 x 5/8" self-tapping screws for key hole slots on the bracket (figure 2). Adjust for fascia board if required.

Do not tighten screws at this time. Leave about 1/8" of clearance between the cabinet top and the under side of the screw head.

**NOTE:** Set backs shown in figure 2 and 4 are for overlay applications (front face of swivel plate flush with cabinet face). For inset applications (2.00" maximum recess), adjust set back to compensate for thickness of the door and fascia board.

**STEP 3**

Install the top assembly using the key hole slots. Adjust for proper set back and tighten the two screws (figure 3).

Check to ensure that the 7/8" minimum distance between the side of the top assembly bracket and the inside wall is maintained.

**STEP 4**

Install eight additional #8 x 5/8" long screws (figure 3).

**BOTTOM ASSEMBLY**

**STEP 5**

Locate and mark the center line of the cabinet bottom (see figure 4).

Measure and mark the center line of left and right hand mounting brackets (figure 4).

Locate and mark for proper set back and additional holes. See note in step 2 for proper set back selection. Pre-drill 5/32" dia. pilot holes for #14 x 3/4" screws (figure 4).

**STEP 6**

Position bottom swivel assembly and extend slightly to access the 2 rear mounting holes. Insert and tighten a screw on each side (figure 5).

Extend slides fully and install remaining six #14 x 3/4" long screws.

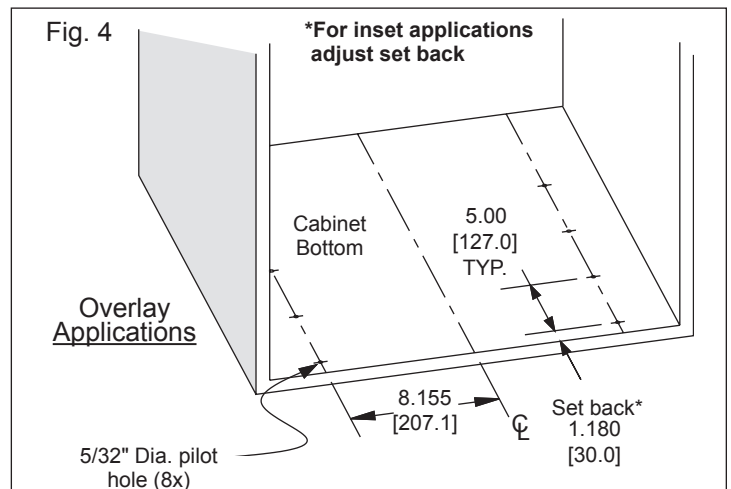
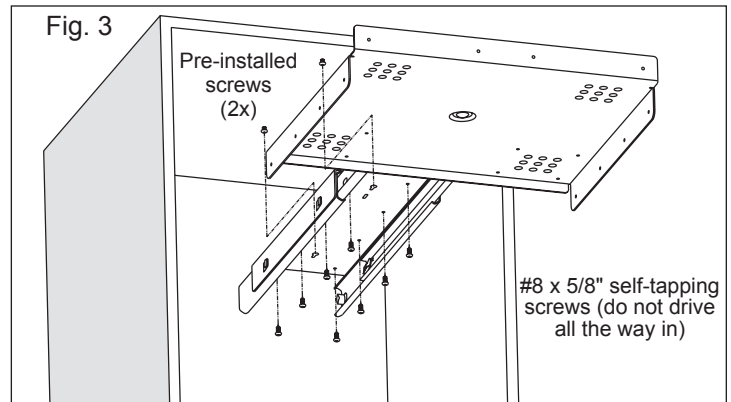
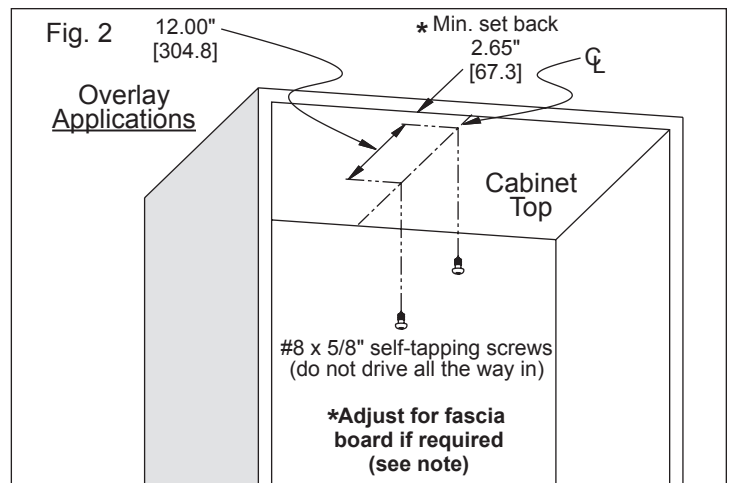
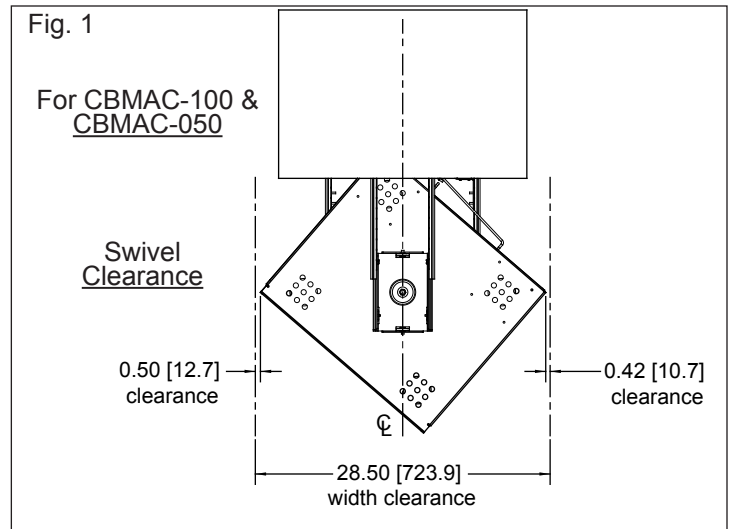

**CABLE CARRIER**

**STEP 7**

Install cable carrier rear hinge plate onto two threaded studs and secure with wing nuts (figure 6).

Extend the swivel plate and rotate to provide clear access to two threaded studs on front of the moving member. Assemble front hinge plate and secure with two wing nuts (figure 6).

Install the cable clips to the back of each shelf using the supplied #8 x 5/8" black screws (figure 7a). Cable clips can be mounted to the top or bottom of the shelf.

**AV BOX INSTALLATION**

**CAUTION: Cabinet must be counterbalanced or secured to the wall or floor before proceeding to step 8.**

**STEP 8**

Extend bottom swivel plate straight out without rotating. Set pull-out box on top of bottom swivel plate. Extend top swivel plate over the top of the pull-out box. Ensure the box is fully seated against the rear flange of top and bottom assemblies.

Secure with 16 each #8 x 5/8" self-tapping screws on top and bottom assemblies (figure 7).

**CABLE MANAGEMENT**

**CAUTION: Ensure cables are supported such that they are not stressed by extension and swivel action, nor tangled in the slide mechanism.**

**STEP 9**

Fully extend the pull-out box and rotate 45° to get access to the cable carrier.

Slip the wires through the wire holder on both cable carrier arms (figure 8). Adjust wire length after feeding wire bundle through the front wire holder. Make sure there is enough cable to allow the pull-out box to fully extend.

**NOTE:** If cables are extremely long or thick, they may get caught in the front cable carrier notch. The pull-out box may not rotate properly or the wire bundle may become damaged if the wires wrap around the front notch.

Attach the wires to the lanyard and route through the cable clip attached to the shelf (figure 8). Use provided cable ties to keep wires together.

**OPTIONAL COOLING FAN** (not supplied by Accuride)

**CAUTION: Consult with a thermal management expert for proper selection and use of a cooling fan for your specific application. Accuride assumes no responsibility for damage to the electronic components as the result of improper selection or use of a cooling fan.**

To expose the vent holes on the top and bottom swivel brackets, bore clearance holes on floor and ceiling of the pull-out box.

Cooling fans are typically attached to the ceiling of the pull-out box from inside (figure 9). Bottom holes can be used to exhaust heat.

Route the wire through the cable clips and wire the holder before plugging in. (see wiring caution on next page).

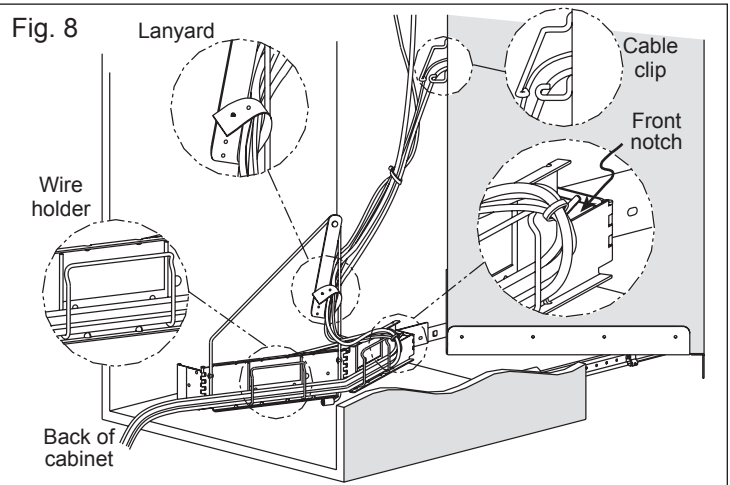
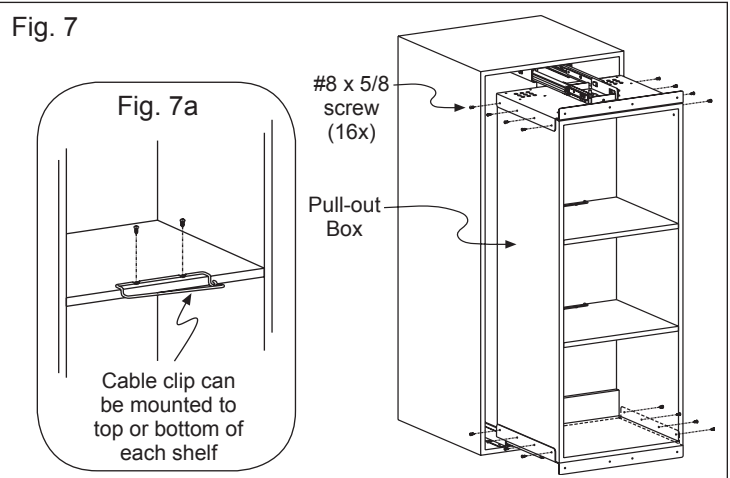
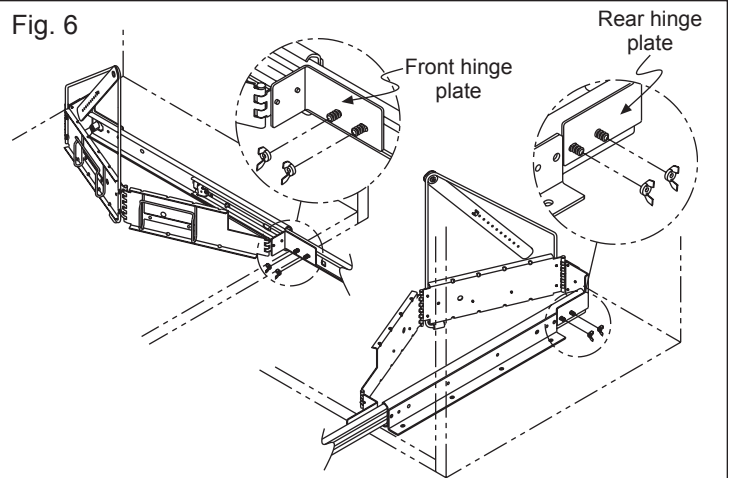
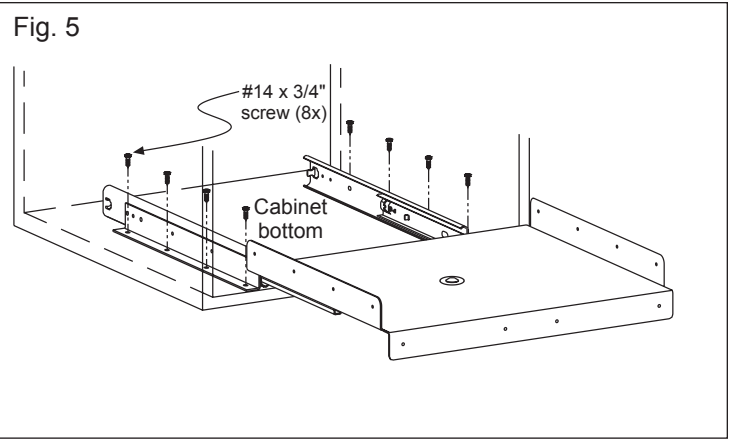
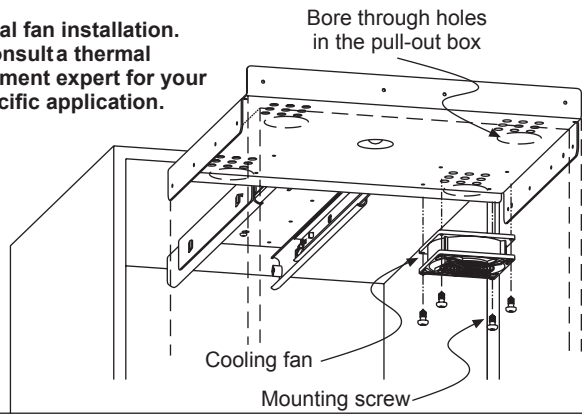

Fig. 9

**Typical fan installation.**  
 Consult a thermal management expert for your specific application.



- Slide members: Cold rolled steel
- Ball retainers: Cold rolled steel
- Ball bearings: Carburized steel

**NOTE:** Specifications, materials, prices, terms, and delivery are subject to change without notice.

**Slide Ordering Instructions**

Complete your order for Accuride model CB MAC-100, Media Access Center, by specifying the following:

1 Each CB MAC -100

Total Units Required \_\_\_\_\_

Media Access Center Part Number \_\_\_\_\_

**Standards/Cautions**

**PLEASE READ THE FOLLOWING**

**CAUTION:**

- This product is capable of carrying the stated loads when the structure into which it is mounted is designed to safely carry such loads.
- The cabinetmaker should ensure the final structure is safe and stable when carrying the maximum intended load. ANSI/BIFMA X5.6 and U.L. 1950 provide standards for static and dynamic load, stability, and endurance testing.
- These and other applicable standards can be obtained from:

American National Standards Institute  
 25 West 43rd Street, 4th Floor  
 New York, NY 10036  
 (212) 642-4900  
 WWW.ANSI.ORG

Business and Institutional Furniture  
 Manufacturer's Association  
 2680 Horizon Drive, SE/Suite A-1  
 Grand Rapids, MI 49546-7500  
 (616) 285-3963  
 WWW.BIFMA.COM

Underwriters Lab  
 1285 Walt Whitman Road  
 Melville, NY 11747-3081  
 (877) 854-3577  
 WWW.UL.COM

**In addition to the above, ensure the following:**

- Ensure cables are supported such that they are not stressed by extension and swivel action, nor tangled in the slide mechanism.
- When fully loaded with the actual intended load, the entire structure must be stable when the sliding unit is fully extended.
- Before loading the unit, ensure the furniture is either counterbalanced or bolted to the floor or wall. This will ensure the furniture does not tip over when the unit is fully loaded and extended.
- Restrain components to the shelves to prevent shifting or tipping as the pull-out box slides in and out.

**Packaging**

The upper and lower assemblies are packaged separately in one big box.

Packaging for lower assembly includes the cable carrier, power strip, and the following kits:

**4180-0545-XE**

- 2 each Cable clip
- 4 each #8-32 wing nut
- 4 each #8 x 5/8" Phillips pan head black screw

**4180-0546-XE**

- 8 each #14 x 3/4" slotted hex washer screw
- 8 each #8 x 5/8" Phillips pan head black screw
- 1 each Load rating sticker

**4180-0461-XE**

- 6 each Cable tie

Packaging for upper assembly includes the following kit:

**4180-0547-XE**

- 18 each #8 x 5/8" Phillips pan head black screw



ACCURIDE INTERNATIONAL INC.

12311 Shoemaker Avenue  
 Santa Fe Springs, CA 90670

TEL (562) 903-0200  
 FAX (562) 903-0208  
 www accuride.com

Manufacturing, Engineering, and Sales

United States • Germany • Japan • Mexico • United Kingdom • China

Copyright © 2007 Accuride International Inc. 3700-9472(1129)-MK103-R2-0907